

3D View of Clip A Conn.

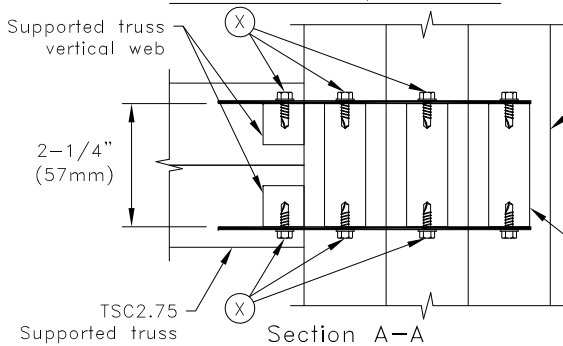

Section A-A

If width of girder vertical web is:  
2-1/4" (57mm) use clip A  
by others.

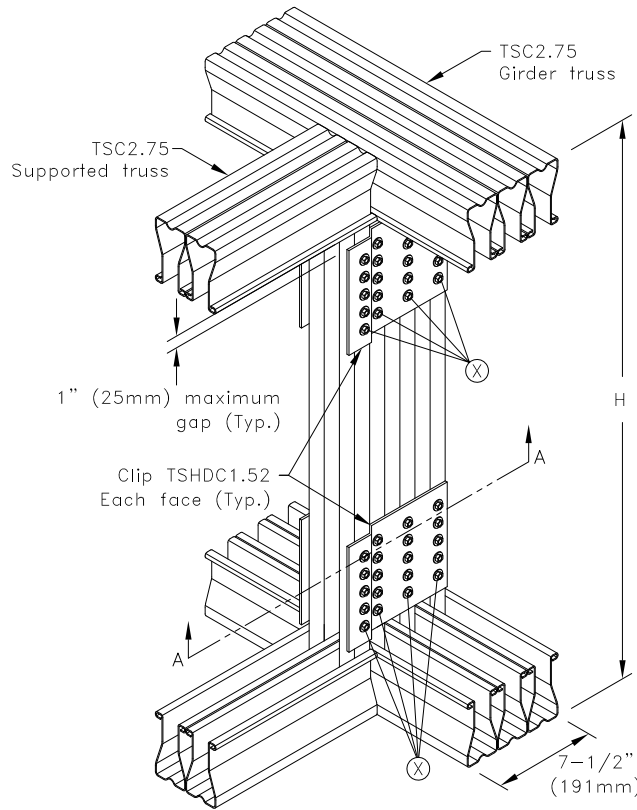

3D View of TSHDC Clip Conn.

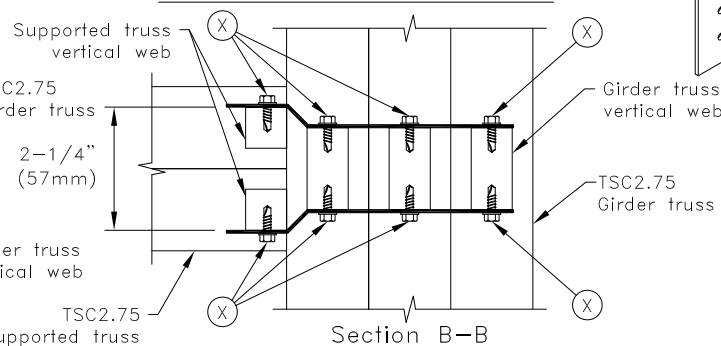

Section B-B

If width of girder vertical web is:  
1-1/2" (38mm) use clip TSHDC1.52

Allowable Reaction and Uplift lbs (kN)	
X <sup>A</sup>	H = 24 in. (610mm) minimum
	R = U lbs (kN)
4	3300 (14.68)
5	3500 (15.57)

A. The quantity "X" refers to the number of #10SDS (Self-Drilling Tapping Screws) that are required on each side of each clip into the web member.

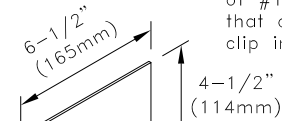

Clip A

16g ASTM A653 SS Grade 33 G60  
Minimum bare metal thickness:  
t = 0.0538" (1.37mm)  
(Supplied by others)

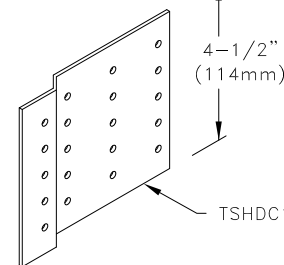

TSHDC1.52

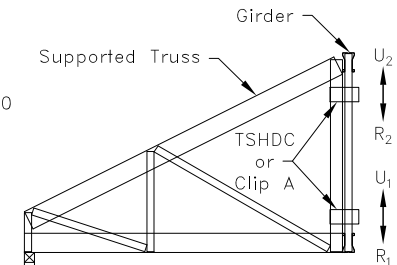

$$R = R_1 + R_2$$

$$U = U_1 + U_2$$

Typical Supported Truss to Girder Connection

General Notes:

1. The top and bottom chords of all trusses shall be properly connected to structural sheathing or purlins, designed by others.
2. Screw spacing, edge distance and end distance is 9/16" (14mm) minimum.
3. The supported truss must be designed utilizing a clip bearing type.
4. R = Allowable Reaction and U = Allowable Uplift, at each clip location.
5. Cold-Formed Steel Calculations are per the 2010 supplement to the AISI 2007 "North American Specifications for the Design of Cold-Formed Steel Structural Members" (S100-07/S2-10).

**TrusSteel**<sup>®</sup>

www.TrusSteel.com

**Heavy 2-Ply TSC2.75  
Truss-To-Truss Connection  
(3 Ply Girder) Tube Webs**

ITW Building Components Group, Inc. shall not be responsible for any performance failure in a connection due to a deviation from this detail. Any variation from this detail shall be approved in advance by ITW Building Components Group, Inc.

**Standard Detail:**

TS061B

**Date:**

07/16/12

**TrusSteel Detail Category:**

Truss-To-Truss Connections

Florida: 1950 Marley Drive / Haines City, FL 33844 / (800) 755-6001  
Missouri: 13389 Lakefront Drive / Earth City, MO 63045 / (800) 326-4102