

Contact a TrusSteel engineer if the approved truss drawing has been analyzed with a bearing under the bottom chord. Resisting uplift at the top chord of the truss changes the truss analysis.

Maximum Allowable Uplift
Capacity lbs. (kN)

4250 (18.90)

Connection offers no
lateral resistance

3/4" (19mm) diameter Hilti HAS
threaded rod with washer and nut.

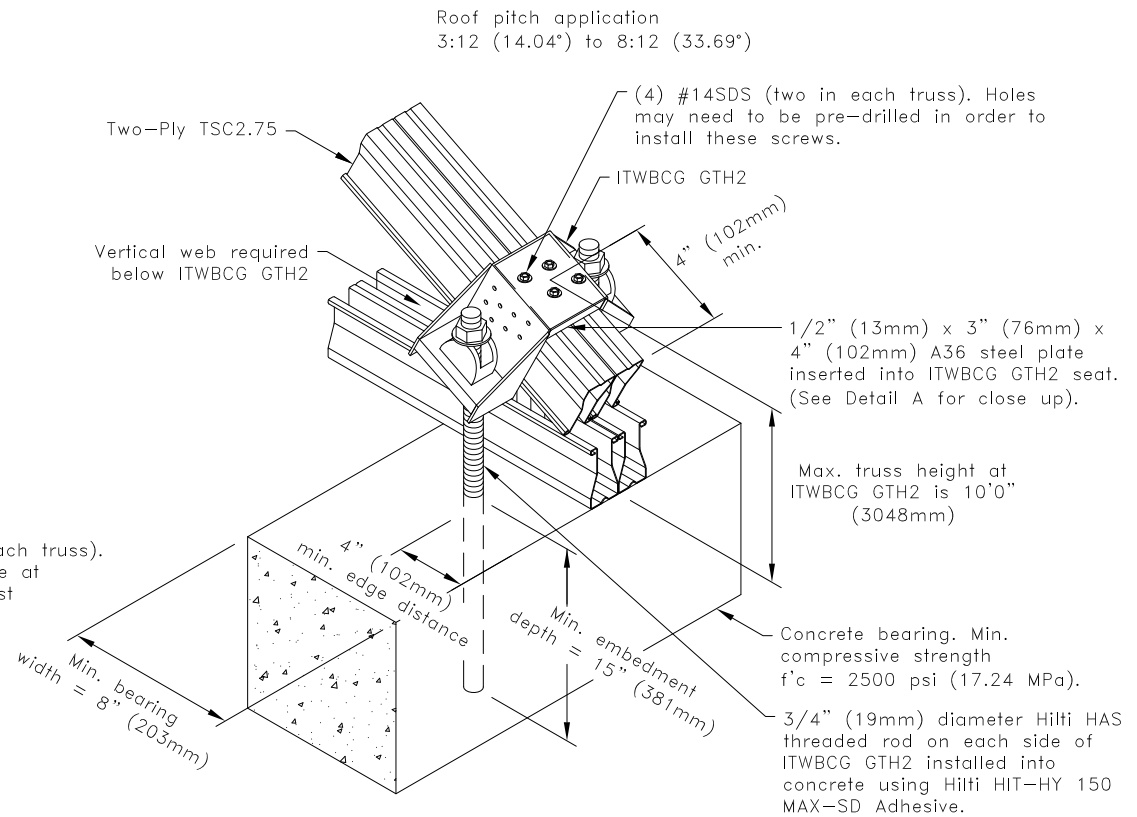
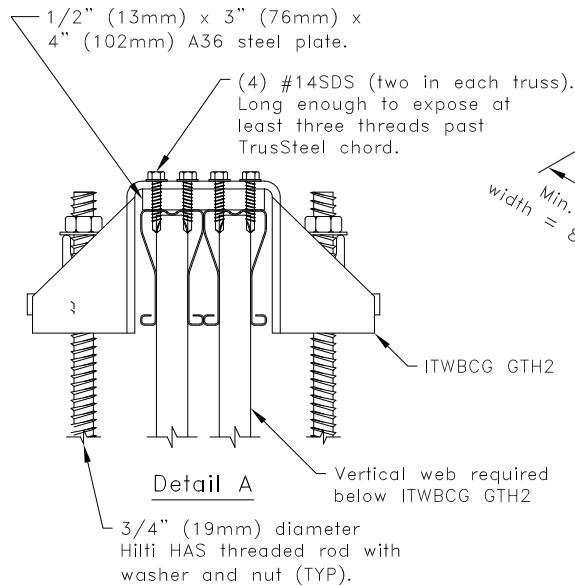
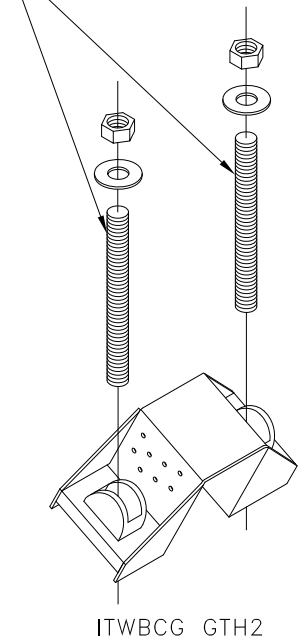

General Notes:

1. Refer to ICC-ES ESR-3013 (April 1, 2010) for proper installation procedures for Hilti HIT-HY 150 MAX-SD Adhesive.
2. Minimum threaded rod length shall be determined by 15" (381mm) minimum embedment and at least three exposed threads above nut on threaded rod.
3. Attachment of second rod assembly on opposite face is identical to what is detailed.
4. SDS = self-drilling tapping screw
5. Per ICC-ES ESR-3013 (April 1, 2011), the design values given above are for uncracked concrete only.
6. Cold-Formed Steel Calculations are per the 2010 supplement to the AISI 2007 "North American Specifications for the Design of Cold-Formed Steel Structural Members" (S100-07/S2-10).

TrusSteel[®]

www.TrusSteel.com

Florida: 1950 Marley Drive / Haines City, FL 33844 / (800) 755-6001
Missouri: 13389 Lakefront Drive / Earth City, MO 63045 / (800) 326-4102

**ITWBCG GTH2 Uplift
Attachment To Concrete**
Two-Ply TSC2.75 With Seat Plate

ITW Building Components Group, Inc. shall not be responsible for any performance failure in a connection due to a deviation from this detail. Any variation from this detail shall be approved in advance by ITW Building Components Group, Inc.

Standard Detail:
TS052

Date:
07/16/12

TrusSteel Detail Category:
Truss-To-Bearing: Concrete