

Sprinkler Pipe Diameter & Hanger Load	
Sprinkler Pipe Diameter in. (mm)	Maximum Hanger Load lbs. (kN) ^B
6 (152)	2630 (11.70)
8 (203)	4060 (18.06)

(B) Values given are based on 15' (4572mm) maximum hanger spacing.

33W1.5x2.0 TS tube vertical support posts. Minimum length to match chord depth plus trapeze. Existing truss web may be used as trapeze support post provided it has been designed to support the load.

(2)600S162-54 grade 50 (unpunched) trapeze members. Space at 15ft (4572mm) maximum. Each end to extend 1/4" (6mm) minimum beyond truss chord.

1/2" (13mm) ASTM A307 threaded rod with washer and nut positioned between tube web stiffeners (see hanger rod assembly detail, this sheet)
Washer inside diameter = 9/16" (14mm)
Washer outside diameter = 1-1/6" (27mm)

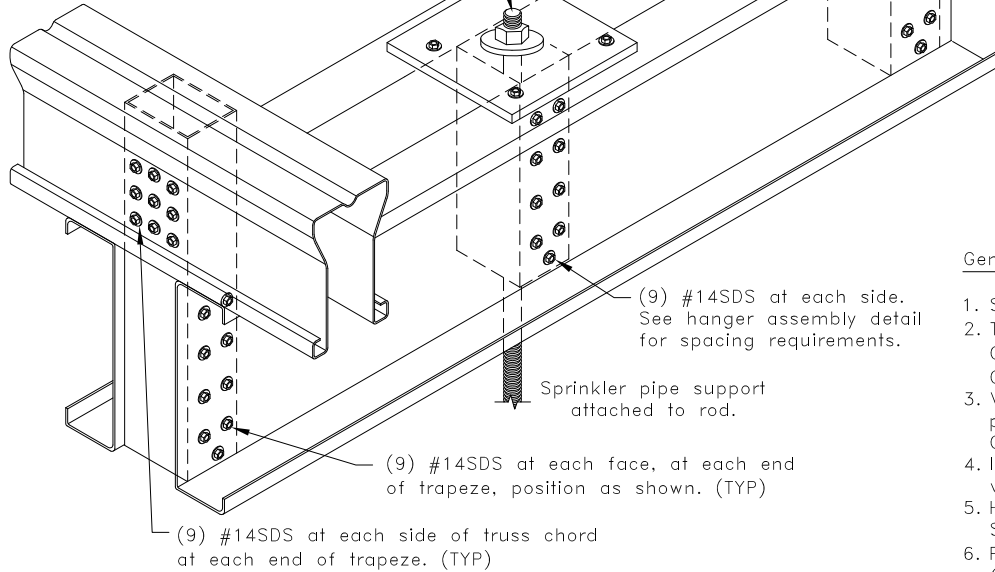

Note: Hanger rod assembly may be placed anywhere along the trapeze.

TSC3.00 or TSC4.00 Truss top chords at 48" (1219mm) O.C. maximum.

Attach plate to each C-stud w/ (2) ITW Buildex TEKS5 12-24

4"x4"x3/8" ASTM A36 steel plate.

(2)600S162-43 grade 50 sprinkler pipe trapeze.

33W1.5x2.0 45ksi (310 MPa) web stiffener at applied load. Length to match depth of trapeze.

ASTM A307 threaded rod with washer and nut at each end. Positioned through web stiffener and trapeze. See hanger loading table for size.

(9) #14SDS at each side at web stiffener. Maintain 3/4" (19mm) minimum vertical spacing and distance from end of stiffener and 7/8" (22mm) minimum horizontal spacing.

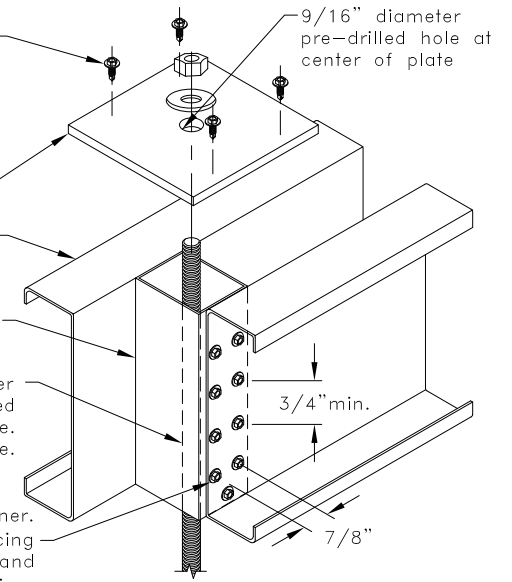

Hanger Rod Assembly Detail

Note: Multiply above units by 25.4 for millimeters.

General Notes:

1. SDS = self-drilling tapping screw. Screw spacing, end and edge distance is 3/4" (19mm) min.
2. The minimum yield strengths of materials are as follows (unless otherwise noted): C-Stud Trapeze = 50ksi (345 MPa), Tube steel support posts = 45ksi (310 MPa), TrusSteel Chords = 55ksi (379 MPa).
3. Values shown are for the sprinkler pipe hanger only. Truss must be properly loaded for sprinkler pipe load. Refer to TrusSteel Technical Bulletin TB00.09.01, "Sprinkler Pipes - Truss Loading & Connections".
4. It is the responsibility of the architect or engineer of record to review this hanger design to verify it conforms with the overall sprinkler system support design.
5. Hanger loads were determined per NFPA13 "Standard For The Installation Of Sprinkler Systems" and assume schedule 40 steel pipe.
6. Pipe hanger spacing shall not exceed 12' (3658mm) for pipes up to and including 1-1/4" (32mm) diameter and 15' (4572mm) for pipes greater than 1-1/4" (32mm) diameter per NFPA13 1999.
7. Nut shall be grade A, HEX conforming to ASTM A563 and Washer shall conform to ASTM F436.
8. Cold-Formed Steel Calculations are per the 2010 supplement to the AISI 2007 "North American Specifications for the Design of Cold-Formed Steel Structural Members" (S100-07/S2-10).

TrusSteel[®]

www.TrusSteel.com

Florida: 1950 Marley Drive / Haines City, FL 33844 / (800) 755-6001
Missouri: 13389 Lakefront Drive / Earth City, MO 63045 / (800) 326-4102

**Double C-Stud Sprinkler Trapeze
at TSC3.00 or TSC4.00 Top Chord
for 8" (203mm) Max. Diameter Pipe**

ITW Building Components Group, Inc. shall not be responsible for any performance failure in a connection due to a deviation from this detail. Any variation from this detail shall be approved in advance by ITW Building Components Group, Inc.

Standard Detail:

TS049K

Date:

07/16/12

TrusSteel Detail Category:

Top Chord Sprinkler Hanger