

Wall Top Plate / Min Thickness	Allowable U lbs (kN) <sup>A</sup>		Allowable P1 lbs (kN) <sup>A</sup>							
			28TSC		33TSC		43TSC		54, 68, 97TSC	
	Clip on One Face <sup>B</sup>	Clip on Both Faces	Clip on One Face	Clip on Both Faces	Clip on One Face	Clip on Both Faces	Clip on One Face	Clip on Both Faces	Clip on One Face	Clip on Both Faces
20g Grade 33 / 0.0328" (0.83 mm)	210 (0.93)	500 (2.22)	530 (2.36)	1060 (4.72)	530 (2.36)	1060 (4.72)	530 (2.36)	1060 (4.72)	530 (2.36)	1060 (4.72)
20g Grade 50 / 0.0328" (0.83 mm)	310 (1.38)	730 (3.25)	620 (2.76)	1230 (5.47)	770 (3.43)	1530 (6.81)	770 (3.43)	1530 (6.81)	770 (3.43)	1530 (6.81)
18g Grade 33 / 0.0428" (1.09 mm)	280 (1.25)	660 (2.94)	620 (2.76)	1230 (5.47)	770 (3.43)	1530 (6.81)	790 (3.51)	1580 (7.03)	790 (3.51)	1580 (7.03)
18g Grade 50 / 0.0428" (1.09 mm)	400 (1.78)	950 (4.23)	620 (2.76)	1230 (5.47)	770 (3.43)	1530 (6.81)	1140 (5.07)	2280 (10.14)	1140 (5.07)	2280 (10.14)
16g Grade 33 / 0.0538" (1.37 mm)	350 (1.56)	820 (3.65)	620 (2.76)	1230 (5.47)	770 (3.43)	1530 (6.81)	1110 (4.94)	2220 (9.88)	1110 (4.94)	2220 (9.88)
16g Grade 50 / 0.0538" (1.37 mm)	400 (1.78)	1190 (5.29)	620 (2.76)	1230 (5.47)	770 (3.43)	1530 (6.81)	1140 (5.07)	2280 (10.14)	1310 (5.83)	2620 (11.65)
14g Grade 33 / 0.0677" (1.72 mm)	400 (1.78)	1040 (4.63)	620 (2.76)	1230 (5.47)	770 (3.43)	1530 (6.81)	1140 (5.07)	2280 (10.14)	1310 (5.83)	2620 (11.65)
14g Grade 50 / 0.0677" (1.72 mm)	400 (1.78)	1230 (5.47)	620 (2.76)	1230 (5.47)	770 (3.43)	1530 (6.81)	1140 (5.07)	2280 (10.14)	1310 (5.83)	2620 (11.65)
12g Grade 33 / 0.0966" (2.45 mm)	400 (1.78)	1230 (5.47) <sup>C</sup>	620 (2.76)	1230 (5.47)	770 (3.43)	1530 (6.81)	1140 (5.07)	2280 (10.14)	1310 (5.83)	2620 (11.65)
12g Grade 50 / 0.0966" (2.45 mm)	400 (1.78)	1230 (5.47) <sup>D</sup>	620 (2.76)	1230 (5.47)	770 (3.43)	1530 (6.81)	1140 (5.07)	2280 (10.14)	1310 (5.83)	2620 (11.65)

- A. Allowable loads shown on this detail are not in combination.  
 B. Uplift connections with clip on one face require a web above connection.  
 C. For 33TSC and greater, U = 1480 lbs (6.58 kN).  
 D. For 33TSC, U = 1530 lbs (6.81 kN). For 43TSC and greater, U = 1960 lbs (8.72 kN).

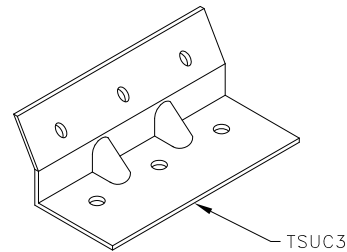
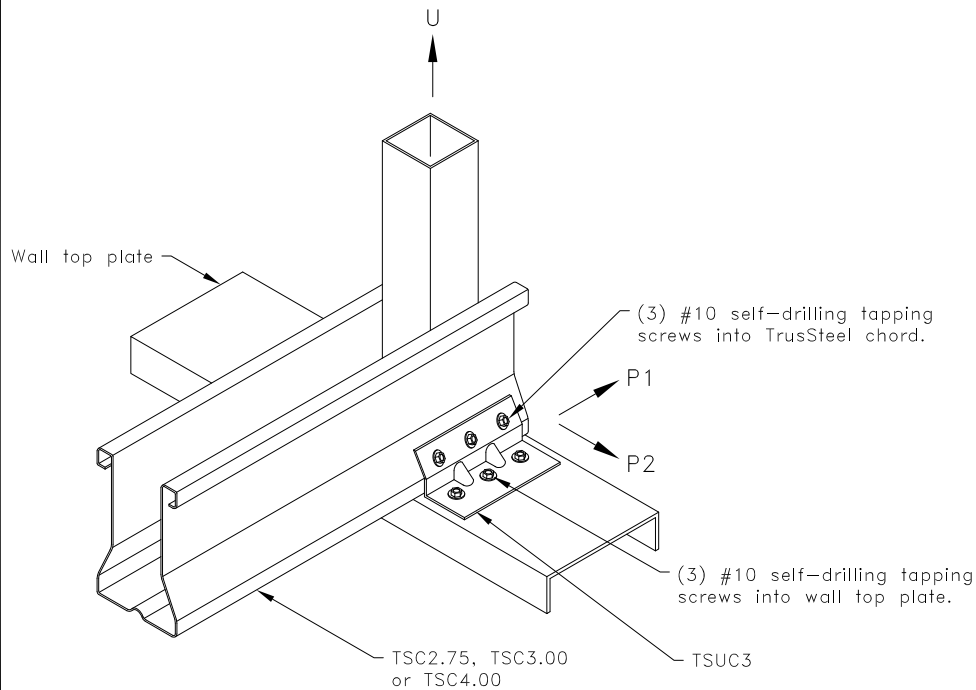

Allowable P2 lbs (kN) <sup>A</sup>		
Chord	Clip on One Face	Clip on Both Faces
28TSC	310 (1.38)	630 (2.80)
33TSC	340 (1.51)	730 (3.25)
≥ 43TSC	340 (1.51)	880 (3.91)

**General Notes:**

- Wall top plate shall be manufactured from cold-formed steel (CFS) with minimum tensile strength of 45 KSI (310 MPa) for grade 33 or 65 ksi (448 MPa) for grade 50 and maximum width of 3-5/8" (92mm).
- Attachment of second clip on opposite face of chord is identical to what is detailed.
- Connection of top plate to wall stud must be capable of transferring truss uplift load from wall top plate to wall stud.
- The wall top plate is to be designed by the job engineer. The wall top plate must be designed to support the loads applied to it (downward, upward and lateral).
- Cold-Formed Steel Calculations are per the 2010 supplement to the AISI 2007 "North American Specifications for the Design of Cold-Formed Steel Structural Members" (S100-07/S2-10).

**TrusSteel**<sup>®</sup>

www.TrusSteel.com

Florida: 1950 Marley Drive / Haines City, FL 33844 / (800) 755-6001  
 Missouri: 13389 Lakefront Drive / Earth City, MO 63045 / (800) 326-4102

**TSUC3 Uplift Attachment To Cold-Formed Steel**

ITW Building Components Group, Inc. shall not be responsible for any performance failure in a connection due to a deviation from this detail. Any variation from this detail shall be approved in advance by ITW Building Components Group, Inc.

**Standard Detail:**  
 TS028

**Date:**  
 07/16/12

**TrusSteel Detail Category:**  
 Truss-To-Bearing: Cold-Formed Steel