

Hanger Parts Table			
Maximum Sprinkler Pipe Dia. 5 in. (127mm)			
Truss Chord Size	Trusses at 24" (610mm) O.C.	Trusses at 48" (1219mm) O.C.	Support Post
	Trapeze Member	Trapeze Member	
TSC2.75	(2) 362S162-43	(2) 362S162-68 <sup>A</sup>	33W.75x1.5
TSC2.75	(2) 600S162-33	(2) 600S162-43	33W.75x1.5
TSC3.00 or TSC4.00	(2) 362S162-43	(2) 362S162-68 <sup>A</sup>	33W1.5x1.5
TSC3.00 or TSC4.00	(2) 600S162-33	(2) 600S162-43	33W1.5x1.5

A. Grade 50 steel required.

Truss top chords at 48" (1219mm) O.C. maximum.

TS tube vertical support posts. See hanger parts table for size. Minimum length to match depth of truss chord plus C-stud. Existing truss web may be used as trapeze support post provided it has been designed to support the load.

Double C-stud (unpunched) trapeze members. See hanger parts table for size. Space at 15ft (4572mm) maximum. End to extend 1/4" (6mm) minimum beyond truss chords.

ASTM A307 threaded rod with washer and nut positioned through tube web stiffener (see hanger rod assembly detail). See hanger loading table for size.

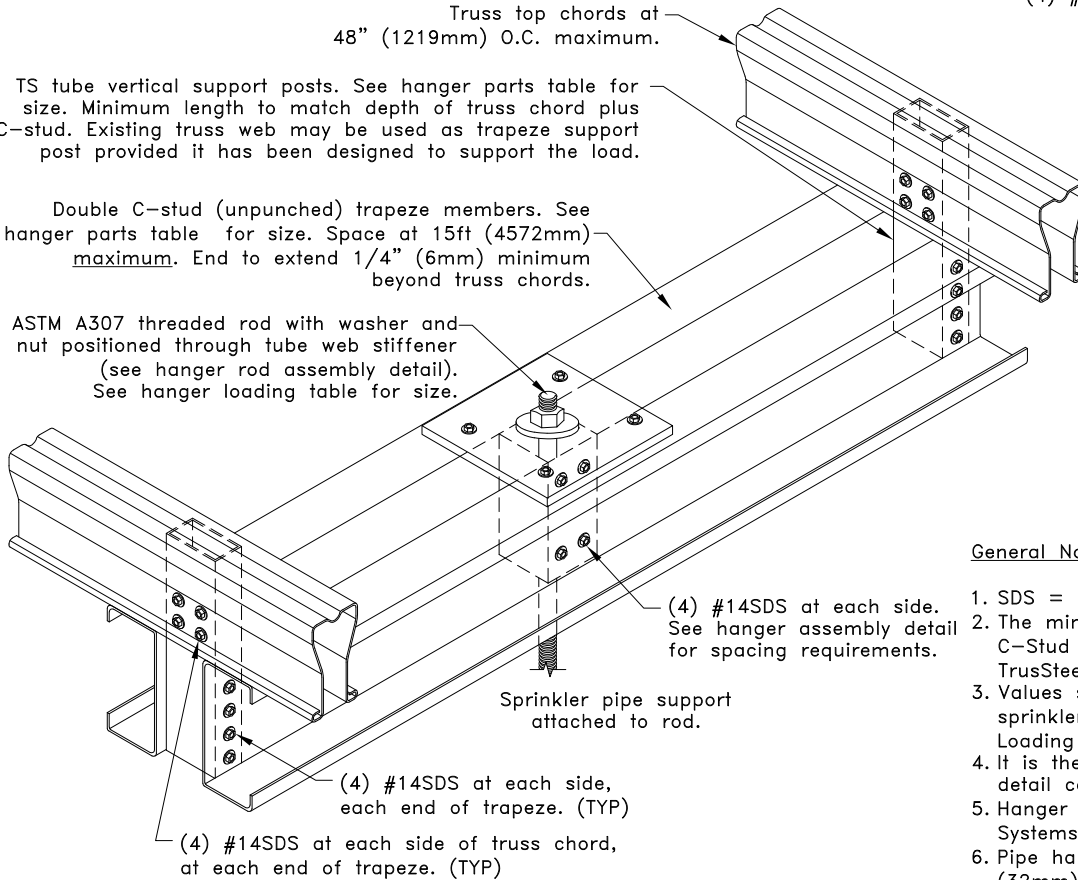

Note: Hanger rod assembly may be placed anywhere along the trapeze.

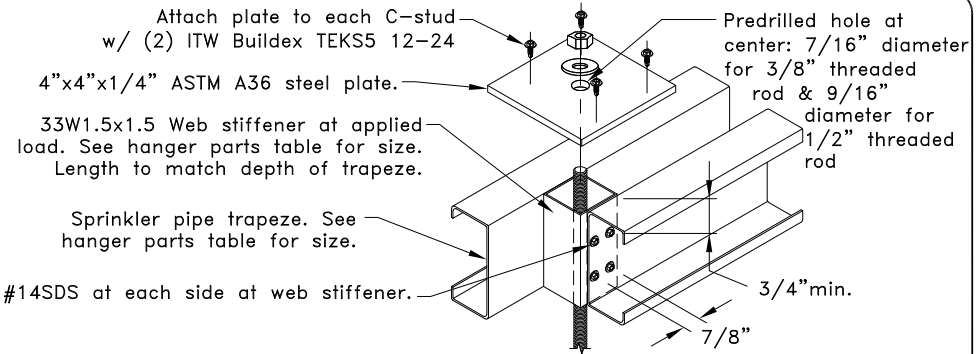

### Hanger Rod Assembly Detail

Note: Multiply above units by 25.4 for millimeters.

Sprinkler Pipe Diameter & Hanger Load		
Sprinkler Pipe Diameter in. (mm)	Maximum Hanger Load lbs. (kN) <sup>B</sup>	Threaded Rod Dia. in. (mm) <sup>C</sup>
2 1/2 (25)	840 (3.74)	3/8 (10)
3 (76)	1060 (4.71)	3/8 (10)
3 1/2 (89)	1260 (5.60)	3/8 (10)
4 (102)	1480 (6.58)	3/8 (10)
5 (127)	2010 (8.94)	1/2 (13)

B. Values given are based on 15' (4572mm) maximum hanger spacing.  
 C. For 3/8" (10mm) diameter threaded rod / nut, washer inside diameter = 7/16" (11mm) and outside diameter = 13/16" (21mm).  
 For 1/2" (13mm) diameter threaded rod / nut, washer inside diameter = 9/16" (14mm) and outside diameter = 1-1/16" (27mm).

#### General Notes:

1. SDS = self-drilling tapping screw. Screw spacing, end and edge distance is 3/4" (19mm) min.
2. The minimum yield strengths of materials are as follows (unless otherwise noted):  
 C-Stud Trapeze = 33ksi (228 MPa), Tube steel support posts = 45ksi (310 MPa),  
 TrusSteel Chords = 55ksi (379 MPa).
3. Values shown are for the sprinkler pipe hanger only. Truss must be properly loaded for sprinkler pipe load. Refer to TrusSteel Technical Bulletin TB00.09.01, "Sprinkler Pipes - Truss Loading & Connections".
4. It is the responsibility of the Building Designer to verify that the hanger design given in this detail conforms with the overall sprinkler system support design.
5. Hanger loads were determined per NFPA 13 2022 "Standard For The Installation Of Sprinkler Systems" and assume schedule 40 steel pipe.
6. Pipe hanger spacing shall not exceed 12 ft (3658mm) for pipes up to and including 1-1/4 in. (32mm) diameter and 15 ft (4572mm) for pipes greater than 1-1/4 in. (32mm) diameter per NFPA 13 2022 "Standard For The installation of Sprinkler Systems".
7. Nut shall be grade A, HEX conforming to ASTM A563 and Washer shall conform to ASTM F436.
8. Cold-Formed Steel calculations are per the 2020 supplement to AISI 2016 "North American Specification for the Design of Cold-Formed Steel Structural Members" (S100-16/S2-20).



www.TrusSteel.com

## Double C-Stud Sprinkler Trapeze at Top Chord for 5" (127mm) Max. Diameter Pipe

Alpine, a division of ITW Building Components Group, Inc. shall not be responsible for any performance failure in a connection due to a deviation from this detail. Any variation from this detail shall be approved in advance by Alpine, a division of ITW Building Components Group, Inc.

#### Standard Detail:

TS049H

Date:

06/01/22

#### TrusSteel Detail Category:

Top Chord Sprinkler Hanger