

Allowable Loads lbs (kN) ^A						
Chord	Clip on one face ^B					
	#10SDS into bottom chord			#12SDS into bottom chord		
	U	P1	P2	U	P1	P2
28TSC2.75	400 ^{C,D} (1.78)	1030 (4.58)	520 (2.31)	400 ^{C,D} (1.78)	1090 (4.85)	570 (2.54)
33TSC2.75		1280 (5.69)	570 (2.54)		1360 (6.05)	
43TSC2.75		1900 (8.45)			2030 (9.03)	
28TSC3.00 or 28TSC4.00	740 ^E (3.29)	1030 (4.58)	520 (2.31)	740 ^E (3.29)	1090 (4.85)	
33TSC3.00 or 33TSC4.00		1280 (5.69)			1360 (6.05)	
43TSC3.00 or 43TSC4.00	740 ^{E,F} (3.29)	1900 (8.45)	570 (2.54)	740 ^{E,F} (3.29)	2030 (9.03)	
54TSC3.00 or 54, 68 & 97TSC4.00		2180 (9.70)			2480 (11.03)	
Chord	Clip on both faces					
	#10SDS into bottom chord			#12SDS into bottom chord		
	U	P1	P2	U	P1	P2
28TSC2.75	2050 (9.12)		1050 (4.67)	2190 (9.74)		1190 (5.29)
33TSC2.75	2550 (11.34)		1210 (5.38)	2720 (12.10)		1380 (6.14)
43TSC2.75	3260 (14.50)	3800 (16.90)	1470 (6.54)	3260 (14.50)	4050 (18.01)	1470 (6.54)
28TSC3.00 or 28TSC4.00	2050 (9.12)		1050 (4.67)	2190 (9.74)		1190 (5.29)
33TSC3.00 or 33TSC4.00	2550 (11.34)		1210 (5.38)	2720 (12.10)		1380 (6.14)
43TSC3.00 or 43TSC4.00	3260 (14.50)	3800 (16.90)	1470 (6.54)	3260 (14.50)	4050 (18.02)	1470 (6.54)
54TSC3.00 or 54, 68 & 97TSC4.00		4360 (19.39)			4950 (22.02)	

A. Allowable loads shown are not in combination.

B. Uplift connections with clip on one face require web above connection. For values in chart, TSC2.75 minimum web is 33W.75x1.5, U = 710 lbs (3.16 kN) or TSC4.00 minimum web is 33W1.5x.75.

C. If web above connection is 33W.75x1.5, U = 710 lbs (3.16 kN).

D. If web above connection is 33W.75x2.25, U = 1030 lbs (4.58 kN).

E. If web above connection is 33C1.5x1.5, U = 1010 lbs (4.49 kN).

F. If web above connection is 33Z1.5x2.50, U = 1590 lbs (7.07 kN).

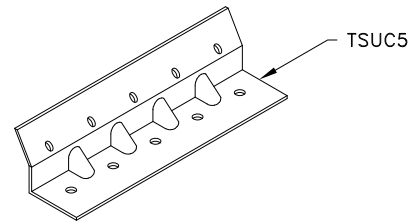
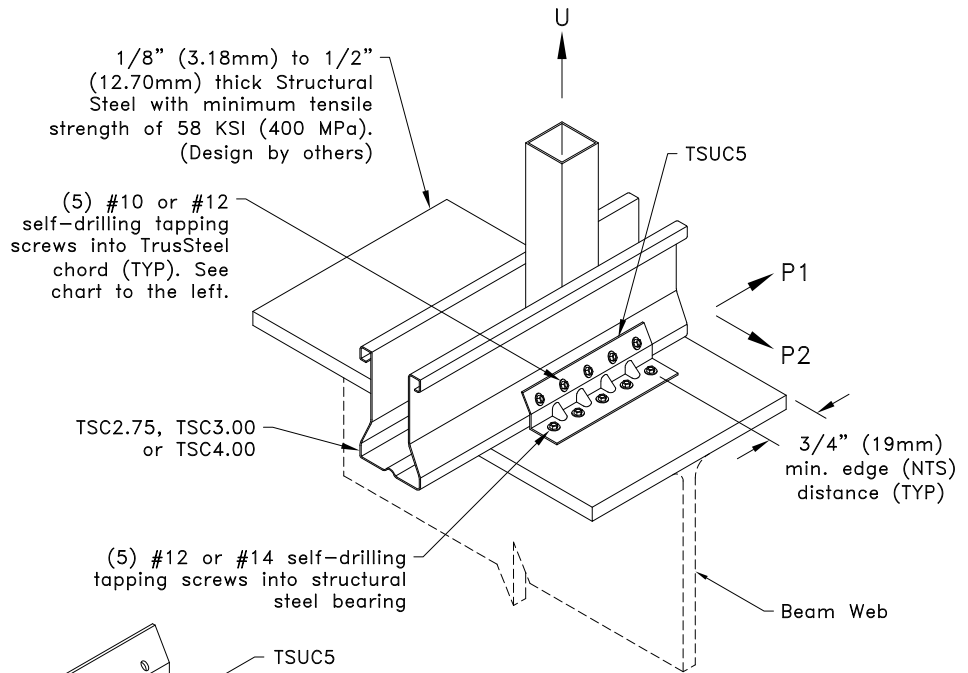

General Notes:

1. If a clip is required on both faces, attach the second clip to the opposite face of the chord as detailed.
2. Multi-ply trusses require a clip on each face. Refer to TrusSteel detail drawing TS023A for ply-to-ply connections for 3-Ply trusses with a clip on each face.
3. Do not overdrive screws. Overdriven screws may strip out TrusSteel chord.
4. Do not drive screws into area of beam flange directly above beam web.
5. To select proper self-drilling tapping screw for structural steel thickness refer to screw manufacturer's recommendations. Refer to manufacturer's specification and code approval regarding proper installation of #12 or #14 self-drilling tapping screws into steel thickness shown above.
6. Cold-Formed Steel calculations are per the 2020 supplement to AISI 2016 "North American Specification for the Design of Cold-Formed Steel Structural Members" (S100-16/S2-20).



www.TrusSteel.com

155 Harlem Ave., North Building, 4th Floor / Glenview, IL 60025 / (800) 755-6001

TSUC5 Attachment To Structural Steel Bearing Using Screws

Alpine, a division of ITW Building Components Group, Inc. shall not be responsible for any performance failure in a connection due to a deviation from this detail. Any variation from this detail shall be approved in advance by Alpine, a division of ITW Building Components Group, Inc.

Standard Detail:
TS048

Date:
06/01/22

TrusSteel Detail Category:
Truss-To-Bearing: Structural Steel