

Allowable Values

Girder Web	Maximum Length of Girder Web in (mm)	Maximum Axial Force in Girder Web lbs (kN)	χ^A	R_H (per supported truss) lbs (kN) ^B	$R = U$ (per supported truss) lbs (kN) ^B
33W1.5x1.5 or 33Z1.5x1.62	56 (1422)	820 (3.65)	4	175 (0.78)	420 (1.87)
33W1.5x2.0 or 33Z1.5x2.50	60 (1524)	860 (3.83)	4	280 (1.25)	420 (1.87)
47W1.5x2.5 or 43Z1.5x3.62	60 (1524)	1350 (6.01)	7	570 (2.54)	680 (3.02)
63W1.5x3.5 or 54Z1.5x3.62	60 (1524)	3540 (15.75)	7	950 (4.23)	1400 (6.23)

- A. The quantity "X" refers to the number of #10SDS required on each side of the girder web, as shown in the cut section view.
 B. R = Supported truss vertical reaction, R_H = Supported truss horizontal reaction, and U = uplift.
 C. $R = R_1 + R_2$
 $U = U_1 + U_2$

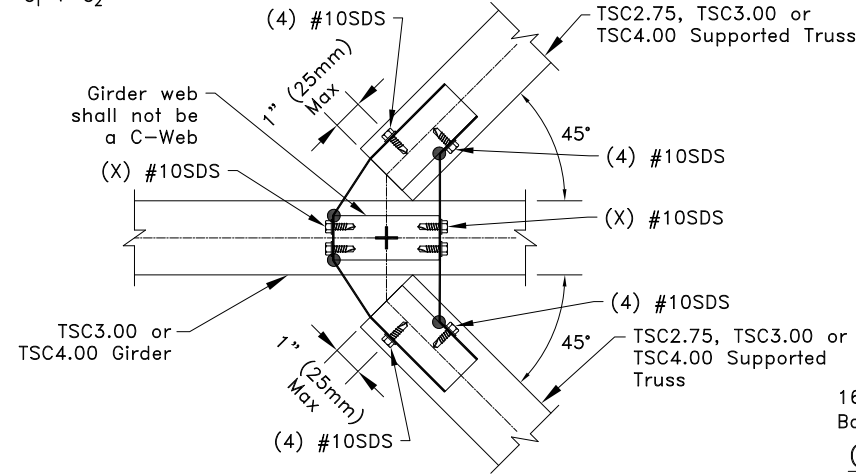
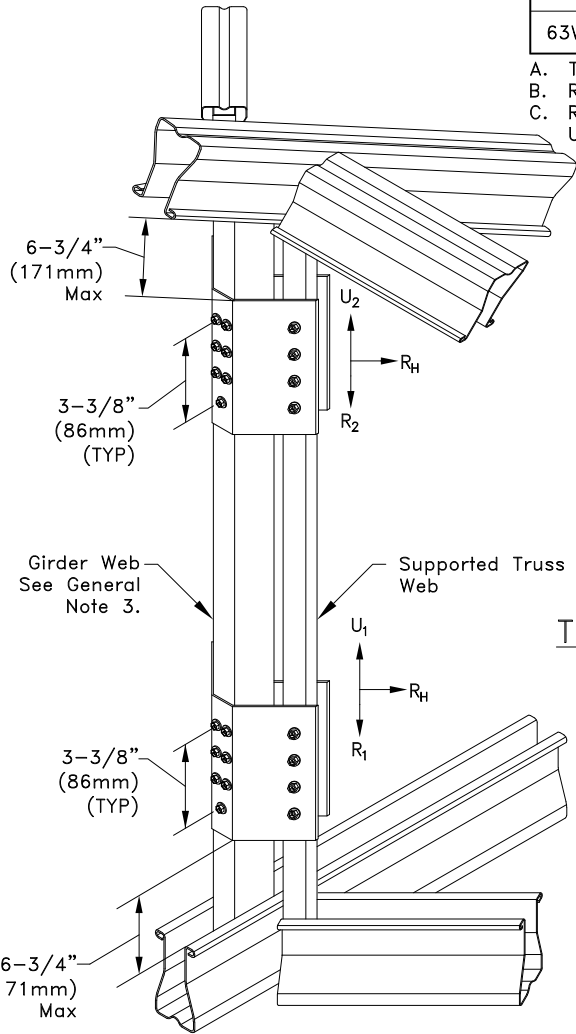

TSC3.00 or TSC4.00 Clip Pair Cut Section

Girder web placement: Center lines of supported trusses line up with center of girder web, as shown above. The girder web center is marked with a + as shown.

16g ASTM A653 SS Grade 50 Class 1 G60
 Bare metal thickness = 0.0538" (1.37mm)

General Clip Information

Clip shape and dimensions are different for each girder web to supported truss web combination. Bend to fit web geometry using brake, or see Technical Bulletin 06.06.28 for a listing of specific dimensions for all possible web combinations.

General Notes:

- If supported truss or girder web is a Z-web, refer to TS068 for connection areas.
- SDS = Self-Drilling Tapping Screw. #10SDS end distance is 9/16" (14mm) and edge distance is 9/32" (7mm). #10SDS shall be spaced a minimum distance of 1-1/8" (29mm) apart vertically and 9/16" (14mm) apart horizontally.
- Girder must be analyzed with concentrated loads from supported trusses in line with center of correctly placed girder webs. "TSC3.00 or TSC4.00 Clip Pair Cut Section" gives correct girder web placement information.
- Two clips must be used for one clip pair. Two clip pairs are required for connection as shown. Supported truss must be analyzed with clip type bearings.
- = Clip Bend; Bend clip only once.
- This connection is for two identical trusses with one truss on each face of the girder web.
- Cold-Formed Steel calculations are per the 2020 supplement to AISI 2016 "North American Specification for the Design of Cold-Formed Steel Structural Members" (S100-16/S2-20).



www.TrusSteel.com

155 Harlem Ave., North Building, 4th Floor / Glenview, IL 60025 / (800) 755-6001

45° Connection For Single Ply TSC3.00 or TSC4.00 Girder (Supported Trusses Have Horizontal and Vertical Reactions)

Alpine, a division of ITW Building Components Group, Inc. shall not be responsible for any performance failure in a connection due to a deviation from this detail. Any variation from this detail shall be approved in advance by Alpine, a division of ITW Building Components Group, Inc.

Standard Detail:
 TS025C

Date:
 06/01/22

TrusSteel Detail Category:
 Truss-to-Truss Connection