

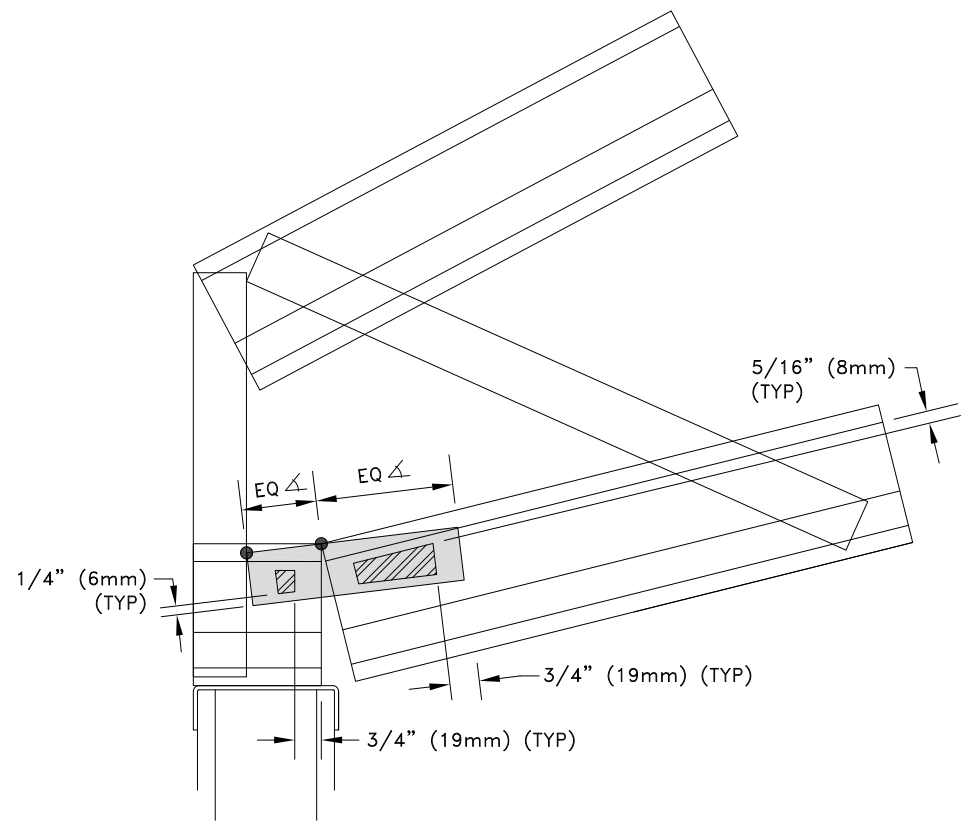

Fasteners Through The Web Area
 Centered Seat Cut Tube and Fastener Placement
 Tube Size: 33W1.5x1.5x6"(152mm)



Fasteners Through The Web Area
 Off-Center Seat Cut Tube and Fastener Placement
 Tube Size: 33W1.5x1.5x6"(152mm)

General Notes:

1. Refer to approved truss drawings for required fastener type and quantities for each fastener contact area.
2. Fastener spacing is 1-1/4" (32mm) and end distance is 3/4" (19mm) minimum, except as shown.
3.  = Fastener contact area.
4. ● = Contact point between Seat Cut Tube and Chord/Web.
5. ∠ = Angle between top of bottom chord and top of Seat Cut Tube.



www.TrusSteel.com

155 Harlem Ave., North Building, 4th Floor / Glenview, IL 60025 / (800) 755-6001

TSC3.00 or TSC4.00
Seat Cut Tube Pitch Break
Connector

Alpine, a division of ITW Building Components Group, Inc. shall not be responsible for any performance failure in a connection due to a deviation from this detail. Any variation from this detail shall be approved in advance by Alpine, a division of ITW Building Components Group, Inc.

Standard Detail:
 TS016F

Date:
 06/01/22

TrusSteel Detail Category:
 Pitch Break Connections